

EAGLE TUGS



OPERATIONS MANUAL

VEHICLE TYPES: eTT MODELS



Read this manual in its entirety before putting your Eagle tow tractor into service. This manual contains important safety instructions. Improper usage or a failure to follow the safety requirements listed in this manual could result in severe injury or death.

1-1 Table of Contents

0-1	Safety Warning
1-1	Table of Contents
2-1	Revision Sheet
3	Introduction
3-1	Welcome
3-2	Contact Info
3-3	Warranty Registration
3-4	Eagle Tugs Warranty
3-5	Proper Use
3-5	Tractor Specifications
3-6	Operator Environment
4	Putting the Tow Tractor Into Service
4-1	Unpacking/Setting Up
5	Instructions for Safe Use
5-1	General Safety Guidelines
5-2	Operator Requirements
5-2	Operator Workstation
5-3	Pre-Operation Inspection
5-4	Operating Instructions
5-5	Instrumentation
5-6	Controls
6	Instructions for safe towing/pushing a load
6-1	Towing
6-1	Pushing
7	Instructions for safe handling
7-1	Emergency Towing
7-2	Tie-Down Procedure
8	CE Marking
8-1	CE Declaration of Conformity

This page intentionally left blank

2-1 Revision Sheet

Revision History

Rev Number	Description	Affected Section(s)	Date
REV00	Initial Release	All	11/16/09
REV01	Wording	All	07/19/10
REV02	Warranty Statement	3	11/16/10
REV03	Contact Information	3	01/29/11
REV04	Warranty Statement	2	01/28/12

Welcome

Welcome to the growing family of EAGLE tractor operators. This tractor was built with the operator's safety, comfort and ease of operation in mind. We hope you agree and enjoy your EAGLE experience.

Purpose & Use of Manual

This manual is designed as a quick guide to familiarize you with the correct and safe operation of your Eagle vehicle as well as to inform you of the preventative maintenance and servicing recommendations of the manufacturer.

Your EAGLE vehicle was designed to do very specific tasks. For that reason, it will look, feel, drive and function differently than over-the-road trucks and automobiles, as well as various other types of vocational vehicles. It is the operator's responsibility to operate this equipment in a safe and prudent manner. Be alert, your and other's safety is involved.

The descriptions and specifications contained in this manual were in effect at the time the manual was printed. EAGLE TUGS reserves the right to discontinue models at any time and/or to change specifications, designs or components used without notice and without incurring obligations.

Contact Information

Corporate Offices

Sales, Support, Customer Service

Eagle Industrial Truck

26111 Northline Rd

Taylor, MI 48180

USA

(734) 442-1000 — (800) 671-0431

Website

www.eagletugs.com contains useful sales and service information. Please refer to this website for the latest revision of this and all other manuals.

Email Addresses

Customer Service customerservice@eagletugs.com

Parts Department parts@eagletugs.com

Technical Support support@eagletugs.com

Sales Department sales@eagletugs.com

Warranty Registration

Please take the time to completely fill out the warranty registration information at our website www.eagletugs.com. It allows Eagle Tugs to contact the appropriate person(s) for future documentation updates, warranty notices, and safety bulletins.

Note: Eagle tugs cannot start a warranty claim without a completed registration card.

Warranty

Please read warranty information carefully.

When contacting Eagle Tugs for warranty or parts service, please have the following information ready:

- Tractor model number
- Tractor serial number
- Current hour reading

This information can be found on the data plate located beside the driver seat with the exception of the hours which can be read using the OPT10 display on the dash.

Battery

Refer to the battery manufacturer's documentation for the traction battery warranty.

3-Year Limited Warranty Information*

The Eagle Tugs (Eagle) 3-Year Warranty covers all TT-series, eTT-series, XL-series, eXL-series and USATS tow tractors, used in aviation applications. Eagle Tugs warrants that these tractors will be free from defects in material and workmanship for a period of 3 years or 3,000 operating hours, with the exception of the electrical system (see electrical component warranty below), from date of delivery to the first customer (or first use), whichever comes first. Written notice of any claimed defect must be given to Eagle within the warranty period and within thirty (30) days after such defect is discovered. Liability under this warranty is limited to either replacing or repairing, at Eagle's election, any part or parts deemed defective after examination by Eagle or an Authorized Service Representative. Any Eagle tractor or any of its parts returned by the customer to Eagle or an Authorized Service Representative via prepaid transportation, and which is found to be defective, will be repaired or replaced and returned to the customer prepaid. On the other hand, should a part be found not defective, inspection and handling charges may be charged to the customer or Authorized Service Representative by Eagle.

Electrical Component Warranty: Electrical components including but not limited to display, starters, alternators and electric fans shall be covered under the respective original manufacturers warranty for each individual component. Copies of the respective warranties are available upon request.

This warranty does not extend to the tires, batteries, and battery chargers as these are warranted directly to the user by their respective manufacturer and not by Eagle or an Authorized Service Representative.

This warranty does not apply to any Eagle tow tractor, or component part(s) that have been subjected to misuse, accident, vandalism, environmental conditions, improper handling or application, maintenance neglect, including lack of lubricants or fluids; nor does it extend to the Eagle tow tractor and/or parts which have been repaired or altered outside of Eagle's plant or the facility of an Authorized Service Representative without the permission of Eagle.

This warranty does not apply to routine maintenance or wearable parts of the Eagle tow tractor such as filters, seals, plugs, hoses, belts, brake pads or shoes, light bulbs, fuses or similar items. Moreover, this warranty does not extend beyond its original term for any Eagle tow tractor or part replaced or repaired under warranty.

This warranty does not cover or provide credit for the following: tractor rental or other substitute equipment; lodging; loss of time, income, sales or profits; loss of the use of tractor; telephone calls or communication expense; lift truck; storage fees; injury or death to persons or damage or destruction of property; or consequential, incidental or punitive damages.

Labor Allowance: A labor allowance may be issued upon request at Eagle's discretion. Allowable labor hours and a per hour labor rate will be determined by Eagle according to reasonable automotive standards.

Warranty Claim Procedure: When a warranty situation arises, it is essential that the customer contact Eagle's Warranty Department at +1 734-442-1000. The customer will need to provide Eagle with the tow tractor serial number and engine hours. A customer service representative will analyze the problem and determine the next steps. In many cases Eagle's technical support personnel will be able to analyze the problem and recommend adjustments that will solve the problem and reduce down time. If further service is required, an Eagle customer service representative will work with customer personnel to arrange a service provider and/or parts be sent to your facility for the repair as quickly as possible.

EXCEPT AS SET FORTH ABOVE, ALL WARRANTIES, CONDITIONS, REPRESENTATIONS, INDEMNITIES AND GUARANTEES, EXPRESS OR IMPLIED, WHETHER ARISING BY STATUTE, CUSTOM OF TRADE OR UNDER ORAL OR WRITTEN STATEMENTS MADE BY OR ON BEHALF OF EAGLE NEGOTIATIONS WITH CUSTOMER, DISTRIBUTOR, DEALER OR ANY REPRESENTATIVE, ARE HEREBY OVERWRITTEN AND EXCLUDED, AND NO LIABILITY SHALL ATTACH TO EAGLE, EITHER IN CONTRACT OR IN TORT, OR STRICT LIABILITY IN TORT, FOR ANY DAMAGE TO PROPERTY, LOSS OF PROFITS, DAMAGES, COSTS, CHARGES, LIABILITY OR EXPENSES, WHETHER DIRECT OR INDIRECT, CONSEQUENTIAL OR OTHERWISE, WHICH ARISE OUT OF OR IN CONNECTION WITH THE SALE OR USE OF ANY EAGLE MACHINE OR THE SUPPLY OF SERVICES.

SUBJECT TO CHANGE WITHOUT NOTICE

Please check our website www.eagletugs.com periodically for service bulletins and manual updates.

*Note - The Eagle Tugs 3-Year Warranty covers TT-series, eTT-series, XL-series, eXL-series and USATS tow tractors used in aviation applications. All MTT and RTT-series, and Transit Pro tow tractors, and all Eagle models which are used in industrial applications, are covered under the Eagle **Standard Warranty** of 1 Year or 2,000 hours. Eagle Bob Tails are covered under Ford Motor Company's Standard Warranty for each respective Ford truck model.

Proper Use of eTT Series Tow Tractors

The eTT line of tow tractors is designed to be an aircraft tow tractor. When used properly in this application, the eTT line of tow tractors will provide years of safe operation. The following activities fall within the approved and anticipated usage:

- Aircraft Towing
- Aircraft Push-back
- Travel on improved surfaces with minimal slope

Never misuse the tow tractor. The tractor has been designed with aircraft towing as the intended usage. Never do any of the following with the tow tractor:

- “Horseplay”
- Racing
- Turn at excessive speed
- Off-road travel or travel on unimproved surfaces
- Drive crossways on a slope or turn on a slope

Vehicle Weights and Performance

Model Number	Year of Manuf.	Mass (lb/kg)		Rated Draw Bar Pull, DBP (lbf/N)		Rated Vertical Hitch Load (lbf/N)	
eTT12 AWD	2009	14,100	6,395	12,000	53,400	500	2,200

Motor	S3 15% Power (hp/kW)		Torque (ft-lb/Nm)	
Danaher 180/4-200	54	40	192	260
	S2 60min (hp/kW)		Torque (ft-lb/Nm)	
	32	24	114	155

3-6 Operator Environment

Operator Vibration Level Data

The operator interface vibration levels on the eTT-series tractor were tested by ISO / IEC 17025 accredited testing lab Kolano and Saha Engineers, Inc. of Waterford, MI, USA.

Kolano and Saha Engineers, Inc.
Project No. 2009-126

TABLE 1

ACCELERATION VALUES

Study Conducted for: EAGLE TUGS

<u>Measurement Location</u>	<u>Operating Condition</u>	<u>Result</u>
Steering Wheel	Vehicle Startup	Values do not exceed 2.5 m/s ²
Steering Wheel	Operating at 1 mph	Values do not exceed 2.5 m/s ²
Seat Bracket	Vehicle Startup	0.95 m/s ² at 414 Hz Normal to the ground.
Seat Bracket	Operating at 1 mph	Values do not exceed 0.5 m/s ²

Measurements were made at 1 Hz bandwidth from 0 to 1000 Hz.

The target values are supplied as a magnitude and do not state over which frequency range it is applicable.

Tests were performed October 29, 2009 on a Model eTT-12 Aircraft Tow Tractor.

Sound Level Data

The eTT-series tow tractor emits the following sound levels:

Model	Peak dBA at Workstation	
	With P/S pump off	Peak P/S noise
eTT12	69	79

The sound level test was performed in a open area on a flat asphalt surface. Readings were taken at the operator workstation, approximate ear height. The following are the test conditions:

SPL Meter:	Tandy, model 33-2055
Ambient Environment:	69 dbA
Temperature:	47°F / 8°C
Dewpoint:	28°F / -2°C
Humidity:	48%
Barometer:	30.18 in / 1021 hPa

EMC Data

Electromagnetic radiation and immunity were tested by Jacobs Engineering, at the Milford Proving Ground facility in Milford, MI, USA.

Electromagnetic Immunity:

Vehicle was subjected to a 10V/m rms electromagnetic field from 30MHz to 1000MHz. No affects were observed on the functionality or operation of the vehicle. This is in conformance with harmonized standard EN 12895:2000.

Electromagnetic Radiation:

The vehicle electromagnetic radiation was measured in accordance with harmonized standard EN 12895:2000 at frequencies from 30MHz to 1000MHz. All data was within limits as laid out in EN 12895:2000.

Unpacking and Setting Up

The following directions specify the correct steps that should be taken once you receive delivery of your eTT series tow tractor. These steps will ensure that the tow tractor will operate safely.

1. Read this entire manual, paying close attention to the safety requirements laid out in it.
2. During the unloading of your tractor, you should note any shipping damage and report it to Eagle Tugs and the shipping company. Verify that all components appear to be in order and undamaged.
3. Remove any documentation (including this manual) from where it is secured to the seat. Dispose of the zip ties.
4. Verify correct tire pressure on all tires
5. Inspect the traction battery cells for water level verifying that the water is between the top of the charge plates and 1/4" below the vent well. Charge the battery to full and do an equalization charge. During or immediately after the equalization charge, water the battery if it was found to be low on water. Refer to the included battery and charger manuals for specific details.



Warning: Never water a cold battery. Only water a battery during the degassing process of an equalization charge, or immediately after an equalization charge. Watering a cold battery will result in overflowing of battery acid which will reduce battery life and dam-

6. Your tow tractor (if equipped) was shipped with two permanent and two removable tie-down rings. If necessary, these rings can be removed using the following directions. Note: you will lose the ability to transport the tractor by removing the tie-down rings.

The rings can be removed by removing the four bolts/nuts that secure the hitch and tie-down ring bracket in place. The hitch then needs to be re-secured using the same bolts and torqued to a value of 85/115 ft-lbs/Nm.

eTT Tie-Down
Ring Location

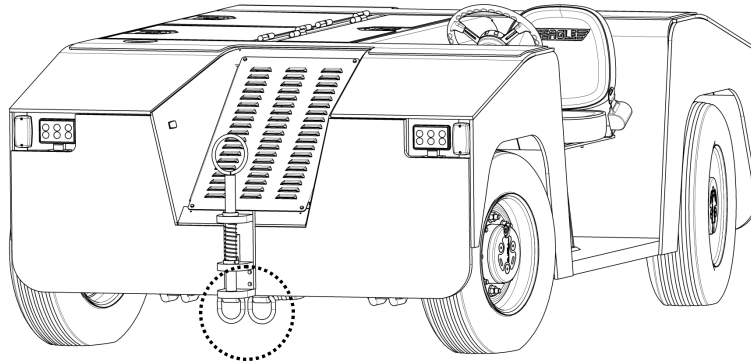

General Safety

The following safety recommendations are not intended to address every possible safety aspect of operating this vehicle, but rather serve as a guide. Eagle has taken extensive measures to make sure that ALL vehicles are designed and tested to be safe when they leave the factory. Modifications made to the vehicle after it leaves the factory can cause the vehicle to be unsafe. In any situation, common sense and caution should always be applied and is ultimately the owner/operator's responsibility.

This tractor is designed to be a dedicated "WORKING" vehicle. It is not designed for or intended to be used for recreational activities, racing or general "horse play activities". Use for any of these inappropriate activities could result in injury, death or damage to the tractor and surrounding objects.



Warning: Failure to comply with the following safety precautions

- Follow all company, facility and OSHA Safety Rules. If you don't have a copy of these, request a copy from your facility management and review them carefully.
- Review carefully and understand the appropriate sections of this manual before starting or operating this tractor.
- Be sure that the tractor is equipped with fully functional safety equipment required in the areas it will be operated. Such items as rotating beacons, back-up alarms, etc. are available from EAGLE's Factory or your local EAGLE distributor.
- Always do the "PRE-OPERATION INSPECTION" before using the tractor.
- Do not begin to operate the tractor if it should have defective lights, horn, brakes, steering or tires. Report irregularities immediately to the proper personnel.

- Your tractor's seat is equipped with retractable seat belts for your safety. Fasten your seat belt and adjust the seat before moving or operating the tractor. Be sure the seat belt is fitted snugly around the hips, not around the waist as failure to do so may cause injury in the event of a collision.
- Shifting between Forward/Reverse and Low/High can only be done when the tractor is stopped. If the tractor is moving, the switches will not respond until the tractor comes to a stop.
- Turn key to OFF position and set parking brake while tractor is unattended.
- If you have not operated this equipment previously, practice driving and operating it in a safe and clear (not congested) area until you are familiar with all aspects of its operation.
- Keep hands and feet away from moving mechanical parts including tires.
- Avoid wearing loose clothing that might get caught in moving parts.
- Check your path of intended motion for personnel and/or possible obstructions, before proceeding.
- When operating the tractor, be particularly cautious when in congested areas. Be alert near blind corners and always anticipate other equipment and personnel movements. Sound the horn when approaching corners.
- Use particular care to operate the vehicle at a safe speed, commensurate with conditions. Speed should always be reduced when entering a turn to assure complete control of the vehicle and any towed loads. Take all corners wide, especially if towing trailers.
- Speed should always be adjusted to allow for a safe and controlled stop, considering the space available for stopping and the weight of the load being moved. Avoid sudden stops.
- Reduce speed when approaching speed bumps.
- Never drive crossways on a slope.
- Avoid operating on bumpy, soft surfaces. Avoid potholes when present.
- Keep clear of the edge of loading docks.

Operator Requirements

The eTT series tow tractor is a piece of industrial equipment and has inherent safety risks. As such, the operator of the tow tractor is expected to have a fork truck or similar license, or be otherwise trained in the usage of material handling equipment.

The operator should read this manual fully before operating the tow tractor.

The operator should be familiar with all aspects of the tow tractor before operating it.

Operator Workstation

Your eTT series tow tractor features an ergonomically designed operator's workstation. This is the only operator workstation on the tractor. Do not sit on or stand on the tractor outside of this area.

The operator should be seated with the seatbelt secured when moving or operating the tractor.

The operator should keep all extremities within the perimeter of the tractor's frame to avoid injury.

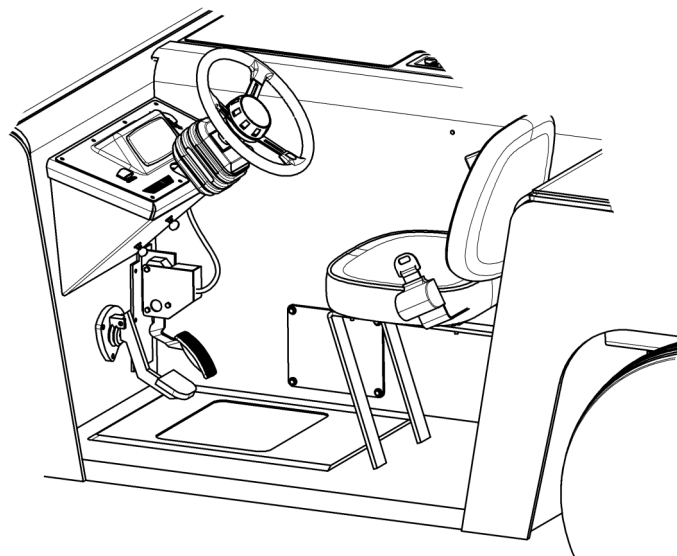

Operator Workstation

Pre-Operation Inspection Checklist

The following inspections should be conducted each day prior to the first operation of the tractor. Additional inspections may be required due to unusual operating conditions.

Walk-A-Round Inspection

- Look for evidence around and under tractor for gear oil, hydraulic fluid or battery acid leaks..
- Check tire rims and wheel stud nuts for possible damage.
- Check tires for under inflation, cuts, breaks or excessive wear and remove any objects stuck in treads.
- Wipe clean, if necessary, all lights, mirrors and reflectors.
- Open battery compartment hood and inspect battery cables.

Inside Drivers Compartment

- Turn key to ON position
- Verify that the tractor is in the intended gear.
- Check display for Errors and Battery state of charge.
- Sound the horn and test for excessive play in the steering wheel.
- Turn on all lights and flashers. Then exit tractor to verify they are operating properly. If the tractor is equipped with a rotating beacon, check if it is functioning.



Warning: Keep hands and clothing away from driveshafts and any other moving parts.



Warning: Any problems noted during inspection should be corrected as soon as possible. Failure to attend to problems promptly could compromise safety and/or the tractor's performance. Do not attempt to make repairs. Contact a qualified mechanic.

Operating the Unit

- With feet firmly on floormat, adjust seat and steering wheel to a comfortable position.
- Sit in operator seat and buckle seat belt.
- Select direction FWD (forward) or REV (reverse) located on dash panel.
- Set parking brake by pulling lever located under the dash.
- Turn key to ON position.
- Check display for Battery charge level and any Error messages.
- Select gear (Low or High) located on dash panel.
- Disengage parking brake by releasing handle under dash panel.
- Check to see all directions are clear.
- Depress accelerator to move tractor.

Turning Unit OFF

- Bring tractor to complete stop.
- Select Forward on the directional switch.
- Set parking brake by pulling lever located under the dash.
- Turn headlights off.
- Turn key to OFF position.

Charging the Unit

- Please refer to the battery and charger manufacturer's instructions for detailed charging instructions.
- Burton connector equipped tractors will automatically disable the tractor when a battery is plugged in. This prevents driving away with the tractor plugged in.



Warning: Open one of the battery hoods when charging to allow battery gases to escape.

5-5 General Usage

eTT Digital Display:

The eTT line of tow tractors features an OPT10 digital display. The OPT10 panel provides many useful features and benefits to the operator. Below, you will find standard operating instructions for the OPT10.

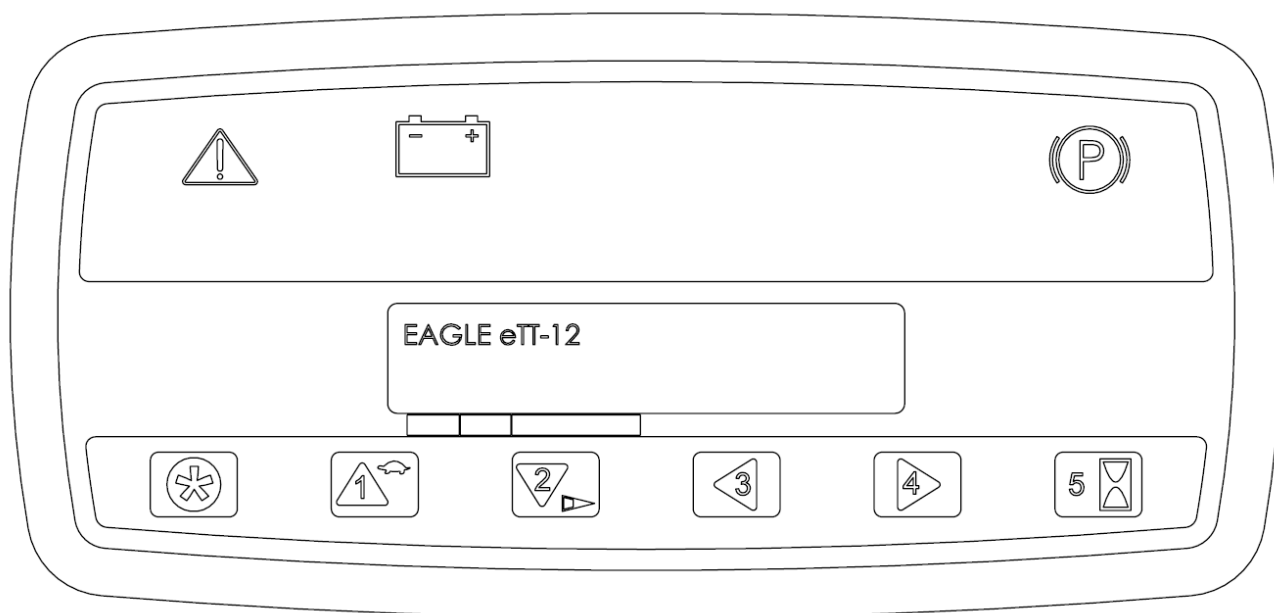

Error Indicator:



Light on display which illuminates indicating an error with tractor operation. The type of error will also display on the menu screen.

Battery Indicator:

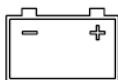

Battery indicator light will illuminate when battery capacity falls below 30% and tractor will be forced into limp mode (speed limit 1 mph) when the battery capacity falls below 20%

Parking Brake Indicator:



When the parking brake indicator is illuminated the parking brake is activated. Note that the accelerator pedal will not function with the parking brake engaged.

Up Button:



By depressing 1 you will be able to scroll Up through the display menu

Down Button:

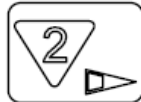

By depressing 2 you will be able to scroll Down through the display menu

Display Menu:



EAGLE eTT-12

The display screen will automatically come on when the key is in the ON position. Using the button labeled 1 to scroll UP through the menu and the button labeled 2 to scroll DOWN through the menu. The menu will display the following.

- Battery charge status
- Miles per hour (mph)
- Traction hours and key-on hours
- Diagnostic codes

Display Maintenance:

- Clean with soap and water
- Do Not pressure wash
- Do Not clean with solvent

Controls:Key Switch:

ON position-The electrical system, accessories and display are activated. Never leave the tractor unattended with the switch in the "ON" position, this can be unsafe, as well as result in discharging the traction battery.

OFF position-This is used to shut off all electrical power (including accessories). Note, there is still some power being drawn by the tractor.



Warning: For long term storage, the battery must be physically disconnected from the truck. Failure to do so will result in battery discharge and possible damage.

Directional Control Rocker Switch:

The Forward and Reverse switch should be set to the desired travel direction. Note: Always be aware of surroundings and which direction the tractor is set to travel.

Gear Select Rocker Switch:

HIGH GEAR: max speed is approx 12 MPH and torque is reduced for unloaded tractor operation.

LOW GEAR: max speed is approx 5 MPH and torque is maximized for loaded tractor operation.

Usage: Use the momentary rocker to switch between gears. The indicator lights show what gear the tractor is currently in. Do not shift gears on a slope without application of the brake.

Light Switch:

Rocker switch located on the dash turns both headlights and taillights on and off.

Inching Switches:

Rocker switch located in sight tunnel on both the front and rear end of tractor. In order for the inching switches to function, the tractor needs to be in LOW GEAR and INCH MODE. Note, shifting is not possible while in INCH MODE.

Note: As a safety feature, the vehicle drive is not enabled at key-on until the tractor is switched to DRIVE MODE. This can prevent the tractor from inching.

The truck features a 5 second delay on the throttle pedal after inching has been last activated. This is intended to increase the safety of using the inching feature.



Warning: Keep body parts away from hitch during inching operation. Failure to do so can result in severe injury.

DRIVE MODE / INCH MODE:

The DRIVE MODE / INCH MODE switch is a safety device that limits the operation of the tractor to one operator at a time. Use DRIVE MODE when operating the tractor from the operator workstation. Use INCH MODE when moving the tractor using the inching switches.

Braking:

Your tractor is equipped with regenerative braking, as well as both front and rear wet disc brakes. The foot brake is power assisted and should be applied with a steady and firm downward pressure.

Parking Brake:

The parking brake is operated by a lever located under the dash. When the parking brake is engaged, the dash symbol will light up on the OPT10, and the tractor will not respond to throttle input.

Note: If the operator leaves the operator's compartment without applying the park-



Warning: Speed should always be adjusted to allow for safe and controlled stops. Adjust your speed based on the surface conditions, the space available for stopping, and the weight of the load being moved. Be aware of you surroundings. Always be prepared to stop and avoid sudden stops.

6-1 Instructions for Safe Towing/Pushing Load

Moving Loads

Maximum capacity towing or pushing of loads must be done with the transmission selector lever in "LOW GEAR"

Load Towing and Pushing Safety

If towing or pushing a load, check to see that:

- The towed load is securely connected to the hitch of the tractor. Be sure hitch is locked/fastened into the closed position.
- The towed cargo load is secure and within the exterior frame of the vehicle that is carrying the load.
- For maximum tractor and load control and stability, as well as towing power, be sure the tongue of the trailer is parallel to the ground when connected to the tractor's hitch.
- Watch the trailer's rear swing clears any obstructions when cornering.

Emergency Towing

If it should be necessary to tow the tractor to a location for maintenance service, be sure that one of the following procedures are followed:

Four Wheel Flat Towing:

- If possible, align the rear wheels using the steering wheel.
- Turn off the truck and disconnect the battery.
- Open the drivetrain access hood.
- Manually shift the transfer case to a neutral position using the manual override access lever (a pair of channel lock pliers can be used).

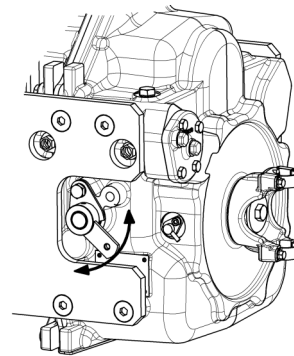
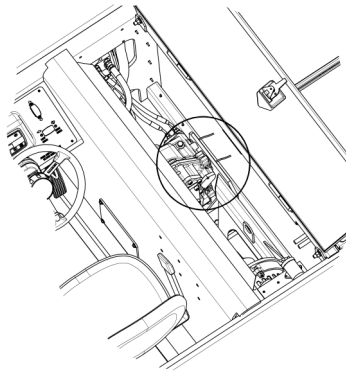

- Release the parking brake via the lever located under the dash.
- The tractor can now be flat towed over short distances

Raised (Two-Wheel) Towing:

- Turn off the tractor and disconnect the battery.
- Remove front and rear driveshafts from the truck. These are the driveshafts between the transfer case and the axles.
- Release the parking brake via the lever located under the dash.
- Using the steering wheel, straighten the front wheels (note: steering effort will be greatly increased over standard operation).
- Secure the steering wheel to maintain the front wheels in a straight location.
- The tractor can now be towed over short distances by lifting the rear wheels and towing on its front wheels.



At no time should the tractor be towed above 5 mph / 8 kph. Towing over 5 mph / 8 kph can result in permanent component damage to the tractor.

Tie Down Procedure

For long distance travel, the eTT-series tow tractor can be transported by trailer. When transporting the tow tractor, please use the following tie-down procedure. This will ensure that the tractor is securely fastened and will prevent damage to the tractor.

- 1) Position tractor on trailer and set Parking Brake.
- 2) Use correctly sized load chains to secure the tractor to the trailer side tie downs - Do not use load straps.
- 3) Run chain through the tie-down rings located behind the E-hitches.
- 4) Take both ends of the chain out and down away from the tractor and tighten as required to secure the tractor.
- 5) Note: chains must not touch front or rear of tractor. Chain contact with the tractor is with the tie-down rings only.
- 6) Do not top load anything on the tractor.
- 7) Do not run straps or chain across the top of the tractor.

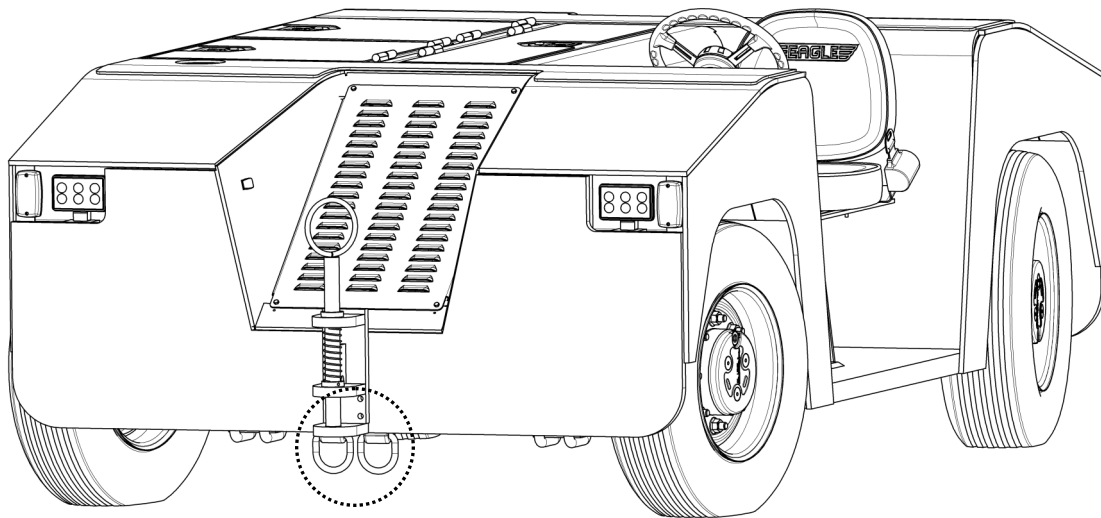

eTT Tie-Down
Ring Location

Troubleshooting

The Eagle eTT-series tow tractor features a digital display that provides feedback on any error conditions that the truck encounters. Below are some of the more common error messages that could be encountered and detailed descriptions.

41: HIGH HYDRAULIC FLUID TEMPERATURE: The hydraulic fluid has exceeded normal operating temperature, let hydraulic fluid cool before continuing use. If error persists, check the electrical connections on the temp sensor mounted in the hydraulic tank.

20: WARNING LOW BATTERY / 42: LOW BATTERY VOLTAGE LEVEL: The tractor battery charge level is low. Charge battery immediately.

14: WARN: TRACTION MOTOR TEMP HIGH: The motor temp has exceeded normal operating temperature. Motor power will be reduced until motor cools. Let the tractor sit to cool before continuing use.

17: WARN: TRACTION HEAT SINK TEMP HIGH: The AC drive temp has exceeded normal operating temperature. Motor power will be reduced until the AC drive cools. Let the tractor sit to cool before continuing use.

See the parts and service manual for additional error messages.

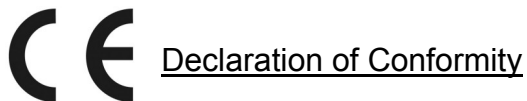

Eagle Industrial Truck, LLC
26111 Northline Road
Taylor, MI 48180

Eagle Tugs certifies that the TT-series of Aircraft Tow Tractors are in conformance with the following European safety directives.

- Machinery Directive 98/37/EC
- Electromagnetic Compatibility Directive 2004/108/EC
- Low Voltage Directive 2006/95/EC
- CE Marking Directive 93/68/EEC

Relevant documentation is maintained by Eagle Industrial Truck and can be furnished upon request.

A handwritten signature in black ink, appearing to read 'Phil Brewer', is positioned above the printed name.

Phil Brewer
Engineering Manager
November 06, 2009

Safety Procedure Review Signature Sheet

By signing below you are verifying that you have read and understand the contents of this manual.

Date:

Printed Name:

Signature:

_____	_____	_____
_____	_____	_____
_____	_____	_____
_____	_____	_____
_____	_____	_____
_____	_____	_____
_____	_____	_____
_____	_____	_____
_____	_____	_____
_____	_____	_____
_____	_____	_____
_____	_____	_____
_____	_____	_____
_____	_____	_____
_____	_____	_____

