

8 7 6 5 4 3 2 1

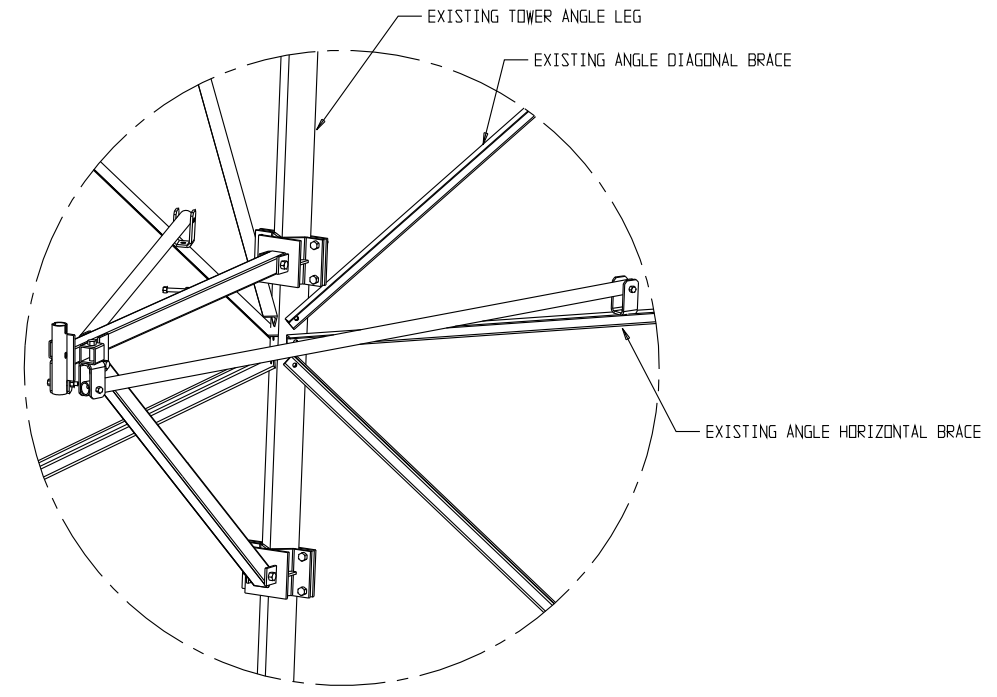

ORIENT MOUNT ASSEMBLY ON TOWER LEG NEAR CONNECTION OF HORIZONTAL OR DIAGONAL MEMBERS

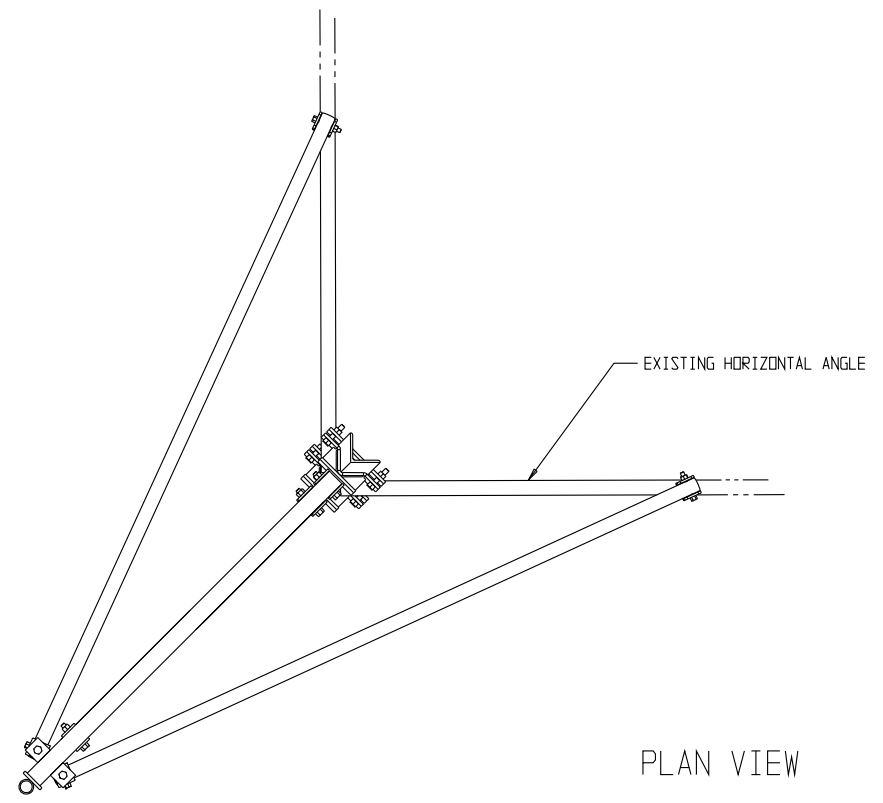
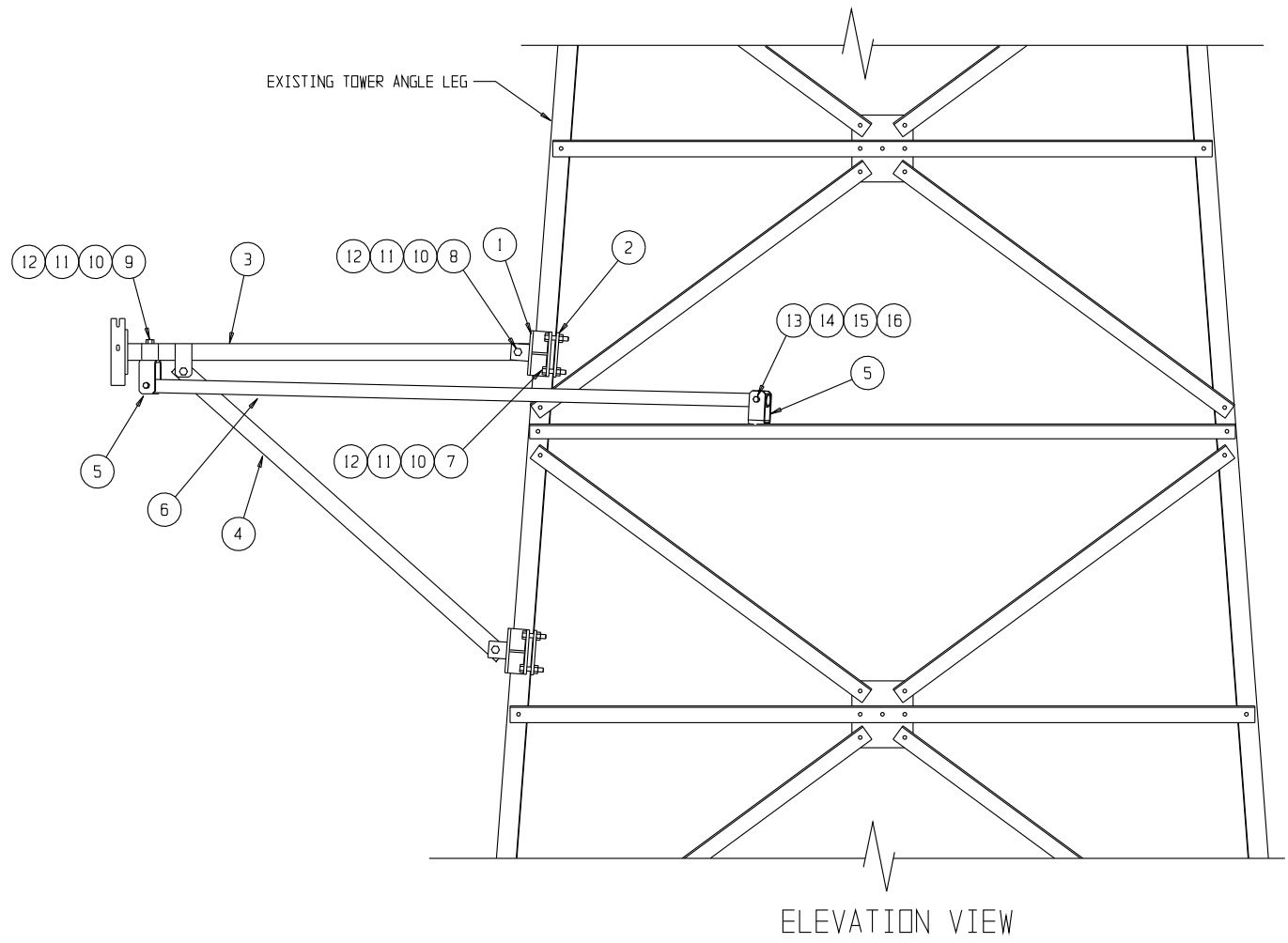

16	4	.	NUT, 5/8-11 UNC HEAVY HEX
15	4	.	WASHER, 5/8 GALV
14	4	.	LOCKWASHER, 5/8 GALV
13	4	.	BOLT, 5/8-11 UNC HEX HEAD GALV X 4 1/2
12	15	.	NUT, 3/4-10 UNC HEAVY HEX
11	15	.	WASHER, 3/4 GALV
10	15	.	LOCKWASHER, 3/4 GALV
9	2	.	BOLT, 3/4-10 UNC HEX HEAD GALV X 2
8	5	.	BOLT, 3/4-10 UNC HEX HEAD GALV X 5
7	8	.	BOLT, 3/4-10 UNC HEX HEAD GALV X 3 1/2
6	2	.	KICK BRACE (PIPE, 2" SCH 80 .218 WALL ASTM A53 GR B)
5	4	.	KICK BRACE BRACKET
4	1	.	DIAGONAL BRACE TUBE (TUBE, 3 X 3 X 1/4 HR ASTM A500 GR B)
3	1	.	STAND OFF MOUNT TUBE WELDMENT
2	2	.	CLAMPING PLATE (1/2 HR ASTM A36 PLATE)
1	2	.	MOUNT PLATE WELDMENT

ITEM	QTY	PART NO.	NOMENCLATURE
RECD	IDENTIFYING NO.	OR DESCRIPTION	
PARTS LIST			
UNLESS OTHERWISE SPECIFIED DIMENSIONS ARE IN INCHES TOLERANCES ARE:			
DECIMALS	ANGLES		
.XX±.06	± 1/2		
.XXX±.030			
STRAIGHT EDGE .008			
FINISH		DO NOT SCALE DRAWING	

APPROVALS		DATE	<p>ASHJIAN TOWER CORPORATION 1775 PARK STREET, BLDG 84, SELMA, CALIF. 93662</p> <p>TITLE WINDTRONICS MOUNT ASSEMBLY BECKMAN TOWER SERVICE</p>			
DRAWN		TAM 02/07/11				
CHECKED						
ENG. APPD.			SIZE	CAGE CODE	DRAWING NO.	REV.
			D		S-1	S-1
			SCALE NONE			SHEET 1 OF 1

8 7 6 5 4 3 2 1

8

7

6

5

4

3

2

1

REVISIONS				
ZONE	REV.	DESCRIPTION	DATE	APPROVED

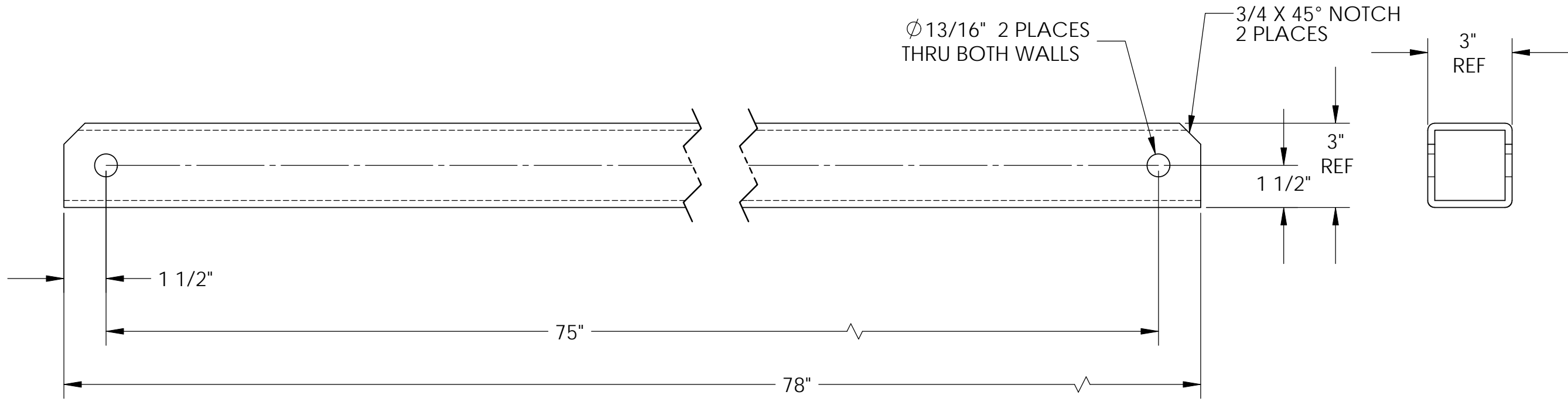
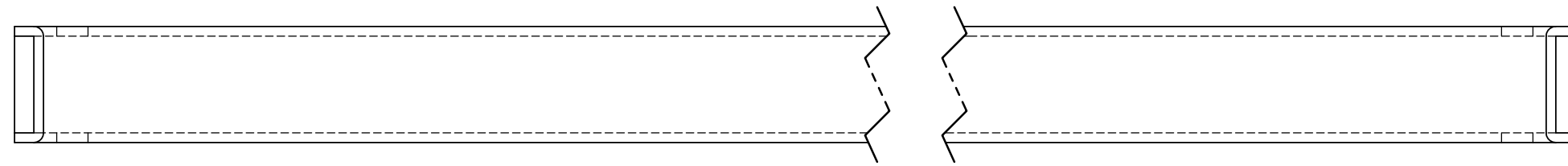

1	6.5	FT	-	TUBE, 3 X 3 X 1/4 ASTM A500 GR B
ITEM	QTY	UNIT	PART NO.	DESCRIPTION
UNLESS OTHERWISE SPECIFIED:				TASHJIAN TOWERS CORPORATION
DIMENSIONS ARE IN INCHES TOLERANCES: FRACTIONAL $\pm 1/32$ ANGULAR: MACH $\pm 25^\circ$ BEND $\pm .5^\circ$ TWO PLACE DECIMAL $\pm .03$ THREE PLACE DECIMAL $\pm .010$				
INTERPRET GEOMETRIC TOLERANCING PER:				CHECKED
MATERIAL AS NOTED				DATE 02/09/09
FINISH ASTM A123 GALV				NAME TAM
NEXT ASSY				COMMENTS:
USED ON				SIZE B
APPLICATION				DWG. NO. -
				REV
				SCALE: 1:4
				WEIGHT:
				SHEET 1 OF 1

PROPRIETARY AND CONFIDENTIAL
 THE INFORMATION CONTAINED IN THIS DRAWING IS THE SOLE PROPERTY OF TASHJIAN TOWERS CORP. ANY REPRODUCTION IN PART OR AS A WHOLE WITHOUT THE WRITTEN PERMISSION OF TASHJIAN TOWERS CORP. IS PROHIBITED.

8

7

6

5

4

3

2

1

REVISIONS				
ZONE	REV.	DESCRIPTION	DATE	APPROVED

Ø11/16" 2 PLACES
THRU BOTH WALLS

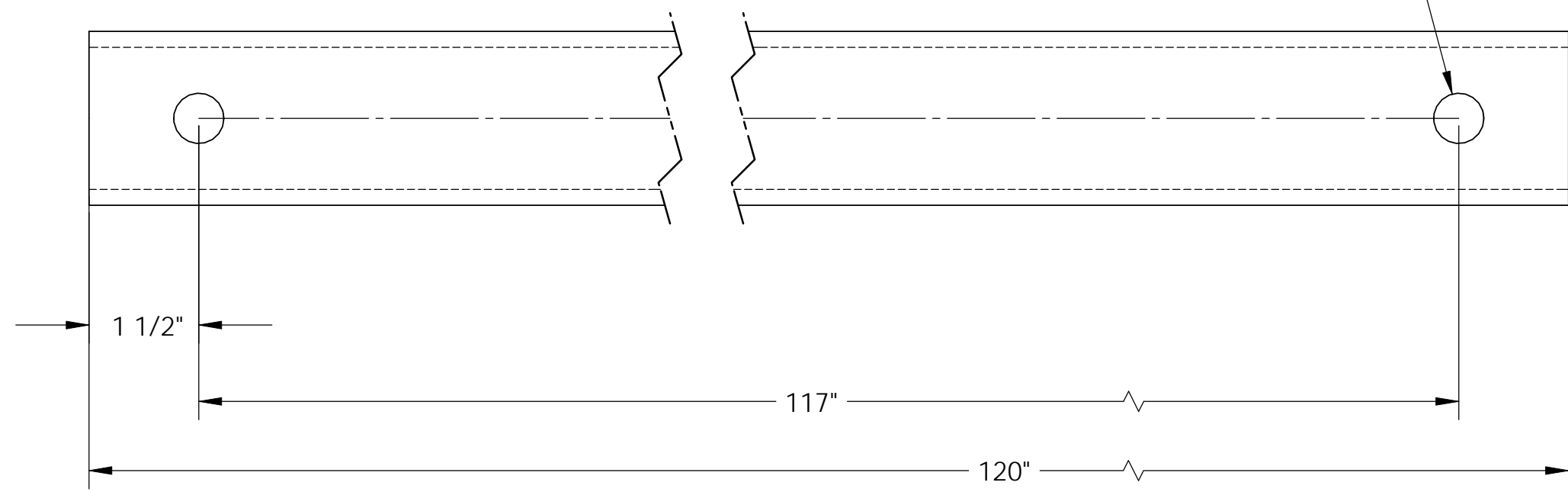

1	10.0	FT	-	PIPE, 2" SCH 80 (.218 WALL) ASTM A53 GR B
ITEM	QTY	UNIT	PART NO.	DESCRIPTION
UNLESS OTHERWISE SPECIFIED:				TASHJIAN TOWERS CORPORATION
DIMENSIONS ARE IN INCHES TOLERANCES: FRACTIONAL ± 1/32 ANGULAR: MACH ± .25° BEND ± .5° TWO PLACE DECIMAL ± .03 THREE PLACE DECIMAL ± .010				
INTERPRET GEOMETRIC TOLERANCING PER:				CHECKED
MATERIAL AS NOTED				DATE 02/09/09
FINISH ASTM A123 GALV				NAME TAM
NEXT ASSY				USED ON
APPLICATION				COMMENTS:
				SIZE B
				DWG. NO.
				REV
				SCALE: 1:2
				WEIGHT:
				SHEET 1 OF 1

PROPRIETARY AND CONFIDENTIAL
THE INFORMATION CONTAINED IN THIS DRAWING IS THE SOLE PROPERTY OF TASHJIAN TOWERS CORP. ANY REPRODUCTION IN PART OR AS A WHOLE WITHOUT THE WRITTEN PERMISSION OF TASHJIAN TOWERS CORP. IS PROHIBITED.

8 7 6 5 4 3 2 1

REVISIONS				
ZONE	REV.	DESCRIPTION	DATE	APPROVED

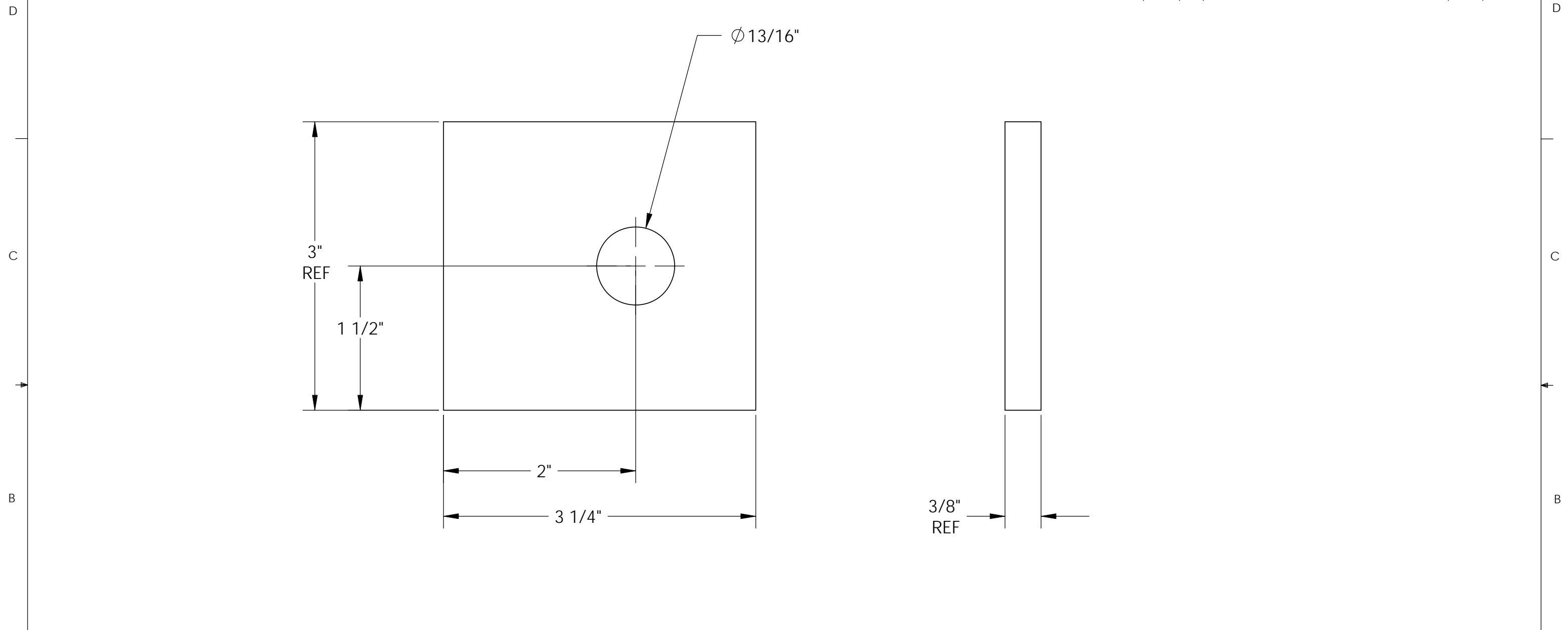

1	0.27	FT	-	BAR, 3/8 X 3 HR ASTM A36 STEEL
ITEM	QTY	UNIT	PART NO.	DESCRIPTION
				UNLESS OTHERWISE SPECIFIED: DIMENSIONS ARE IN INCHES TOLERANCES: FRACTIONAL ± 1/32 ANGULAR: MACH ± .25° BEND ± .5° TWO PLACE DECIMAL ± .03 THREE PLACE DECIMAL ± .010
				INTERPRET GEOMETRIC TOLERANCING PER:
				MATERIAL AS NOTED
				FINISH
				APPLICATION
<p>PROPRIETARY AND CONFIDENTIAL THE INFORMATION CONTAINED IN THIS DRAWING IS THE SOLE PROPERTY OF TASHJIAN TOWERS CORP. ANY REPRODUCTION IN PART OR AS A WHOLE WITHOUT THE WRITTEN PERMISSION OF TASHJIAN TOWERS CORP. IS PROHIBITED.</p>				<p>TASHJIAN TOWERS CORPORATION TITLE: LEG MOUNT EAR</p>
				CHECKED DATE NAME COMMENTS: DRAWN 02/09/09 TAM
				ENG APPR. Q.A. MFG APPR.
				SIZE DWG. NO. REV B -
				SCALE: 1:1 WEIGHT: SHEET 1 OF 1

8 7 6 5 4 3 2 1

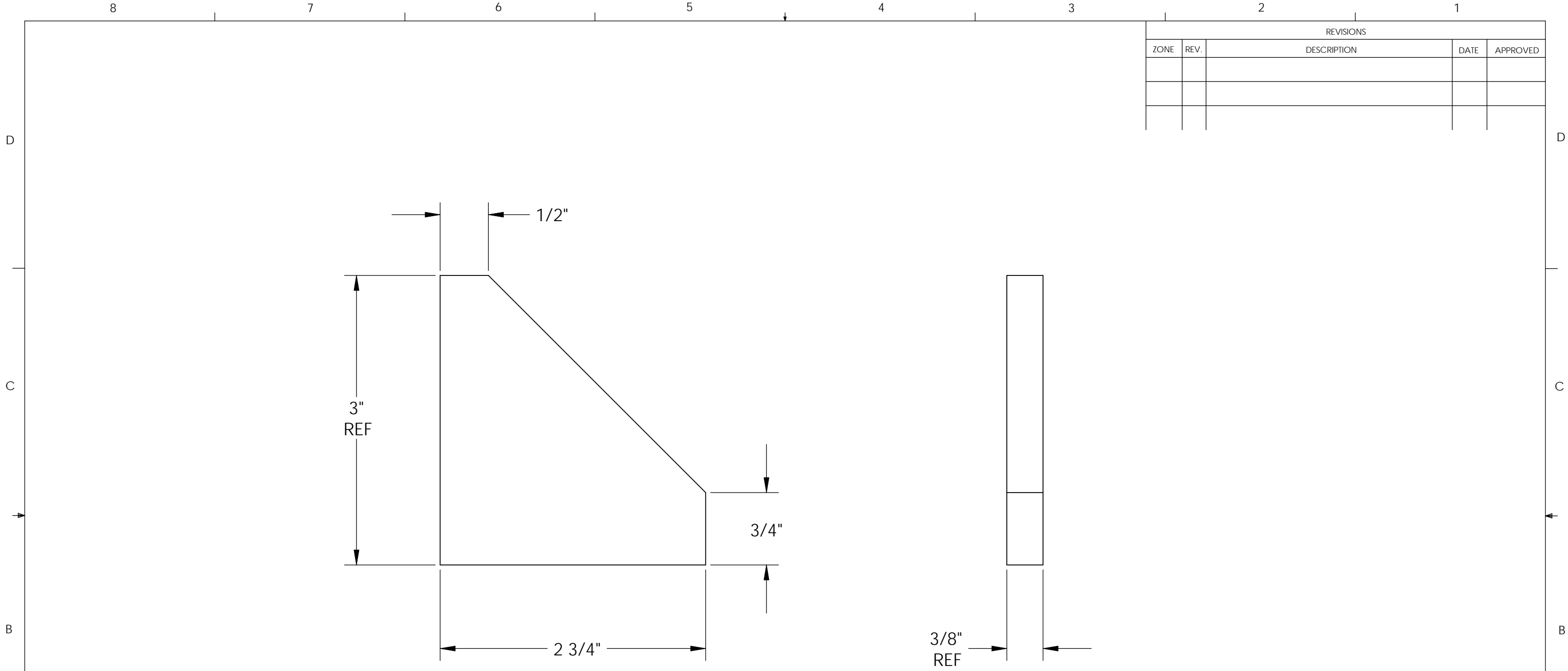

REVISIONS				
ZONE	REV.	DESCRIPTION	DATE	APPROVED

1	0.23	FT	-	BAR, 3/8 X 3 HR ASTM A36 STEEL
ITEM	QTY	UNIT	PART NO.	DESCRIPTION
				UNLESS OTHERWISE SPECIFIED: DIMENSIONS ARE IN INCHES TOLERANCES: FRACTIONAL ± 1/32 ANGULAR: MACH ± .25° BEND ± .5° TWO PLACE DECIMAL ± .03 THREE PLACE DECIMAL ± .010
				INTERPRET GEOMETRIC TOLERANCING PER:
				MATERIAL AS NOTED
				FINISH
				APPLICATION
				TASHJIAN TOWERS CORPORATION
				TITLE: MOUNT GUSSET
				CHECKED
				DATE
				NAME
				COMMENTS:
				DRAWN
				02/09/09
				TAM
				ENG APPR.
				Q.A.
				MFG APPR.
				SIZE
				DWG. NO.
				REV
				SCALE: 1:1
				WEIGHT:
				SHEET 1 OF 1

PROPRIETARY AND CONFIDENTIAL
 THE INFORMATION CONTAINED IN THIS DRAWING IS THE SOLE PROPERTY OF TASHJIAN TOWERS CORP. ANY REPRODUCTION IN PART OR AS A WHOLE WITHOUT THE WRITTEN PERMISSION OF TASHJIAN TOWERS CORP. IS PROHIBITED.

8 7 6 5 4 3 2 1

REVISIONS				
ZONE	REV.	DESCRIPTION	DATE	APPROVED

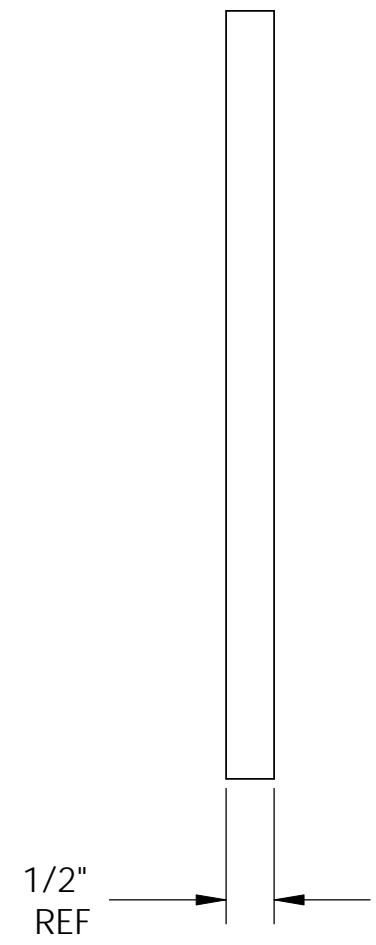
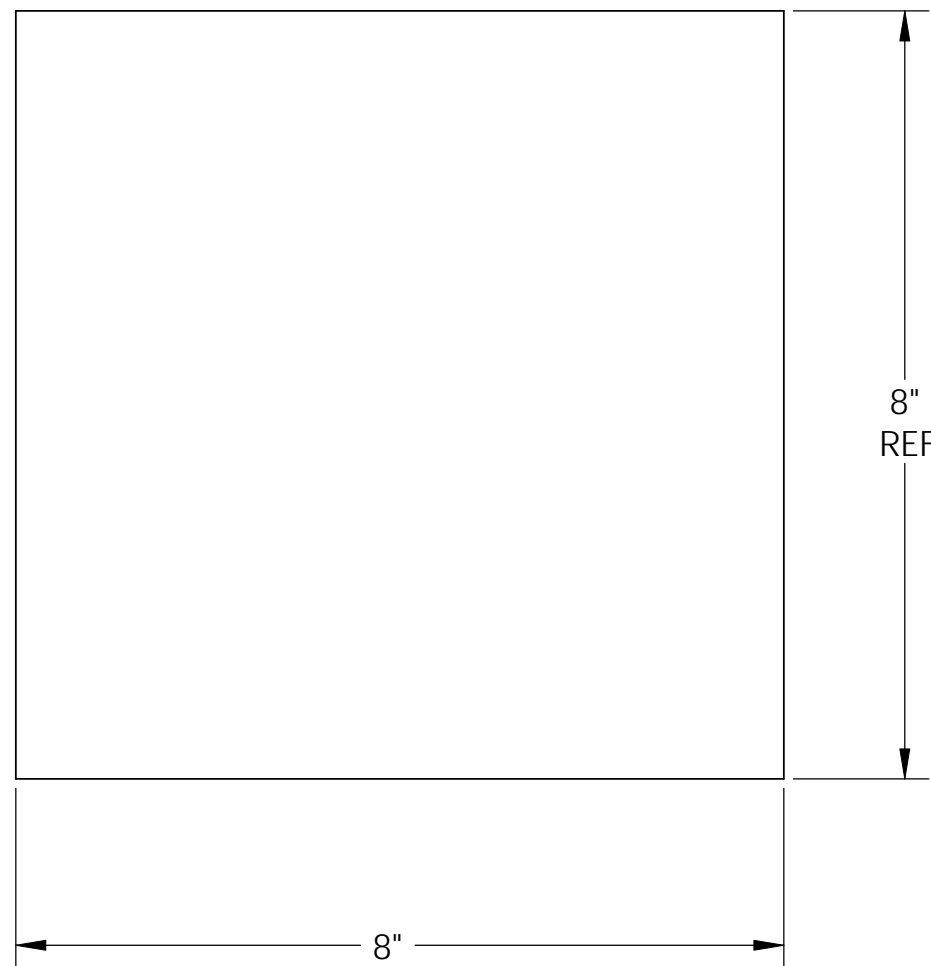

ALT MAT'L: PLATE, 1/2 HR ASTM A36 STEEL

1	0.67	FT	-	BAR, 1/2 X 8 HR ASTM A36 STEEL																				
ITEM	QTY	UNIT	PART NO.	DESCRIPTION																				
				UNLESS OTHERWISE SPECIFIED: DIMENSIONS ARE IN INCHES TOLERANCES: FRACTIONAL ± 1/32 ANGULAR: MACH ± .25° BEND ± .5° TWO PLACE DECIMAL ± .03 THREE PLACE DECIMAL ± .010																				
				INTERPRET GEOMETRIC TOLERANCING PER:																				
				MATERIAL AS NOTED																				
				FINISH																				
				APPLICATION																				
<p>TASHJIAN TOWERS CORPORATION</p> <p>TITLE: MOUNT PLATE</p>				<table border="1"> <tr> <th>CHECKED</th> <th>DATE</th> <th>NAME</th> <th>COMMENTS:</th> </tr> <tr> <td>DRAWN</td> <td>02/09/09</td> <td>TAM</td> <td> </td> </tr> <tr> <td>ENG APPR.</td> <td> </td> <td> </td> <td> </td> </tr> <tr> <td>Q.A.</td> <td> </td> <td> </td> <td> </td> </tr> <tr> <td>MFG APPR.</td> <td> </td> <td> </td> <td> </td> </tr> </table>	CHECKED	DATE	NAME	COMMENTS:	DRAWN	02/09/09	TAM		ENG APPR.				Q.A.				MFG APPR.			
CHECKED	DATE	NAME	COMMENTS:																					
DRAWN	02/09/09	TAM																						
ENG APPR.																								
Q.A.																								
MFG APPR.																								
				<table border="1"> <tr> <th>SIZE</th> <th>DWG. NO.</th> <th>REV</th> </tr> <tr> <td>B</td> <td>-</td> <td> </td> </tr> </table>	SIZE	DWG. NO.	REV	B	-															
SIZE	DWG. NO.	REV																						
B	-																							
				<table border="1"> <tr> <th>SCALE: 1:2</th> <th>WEIGHT:</th> <th>SHEET 1 OF 1</th> </tr> </table>	SCALE: 1:2	WEIGHT:	SHEET 1 OF 1																	
SCALE: 1:2	WEIGHT:	SHEET 1 OF 1																						

PROPRIETARY AND CONFIDENTIAL
THE INFORMATION CONTAINED IN THIS DRAWING IS THE SOLE PROPERTY OF TASHJIAN TOWERS CORP. ANY REPRODUCTION IN PART OR AS A WHOLE WITHOUT THE WRITTEN PERMISSION OF TASHJIAN TOWERS CORP. IS PROHIBITED.

8 7 6 5 4 3 2 1

D
C
B
A

D
C
B
A

REVISIONS

ZONE	REV.	DESCRIPTION	DATE	APPROVED

HOLES TO BE INLINE WITHIN 0.01

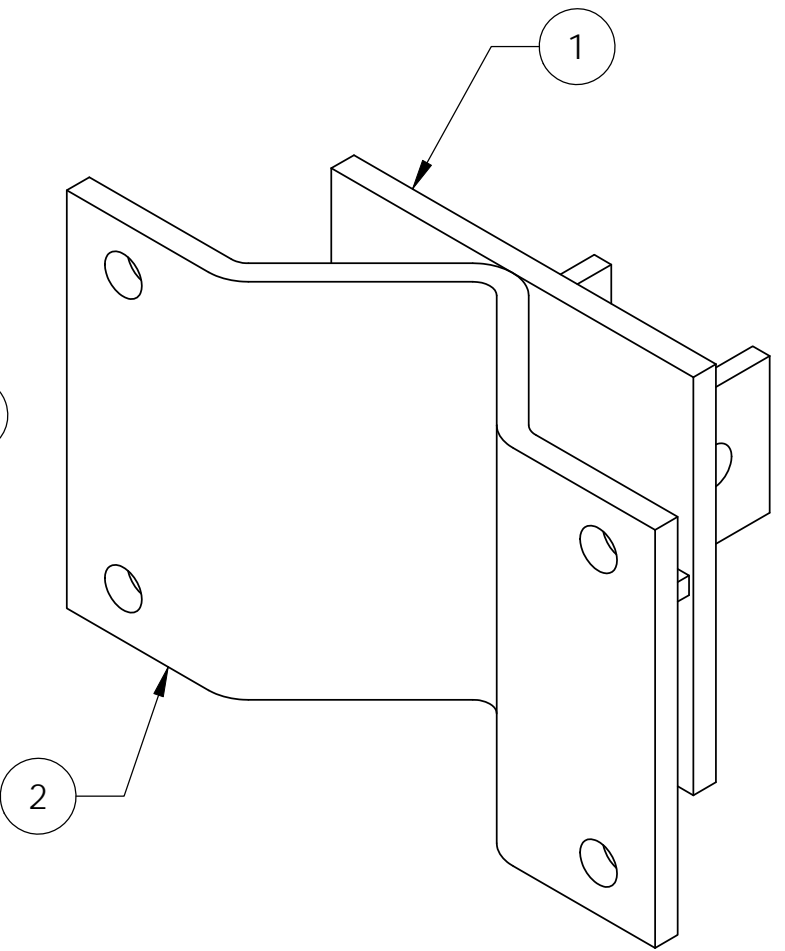
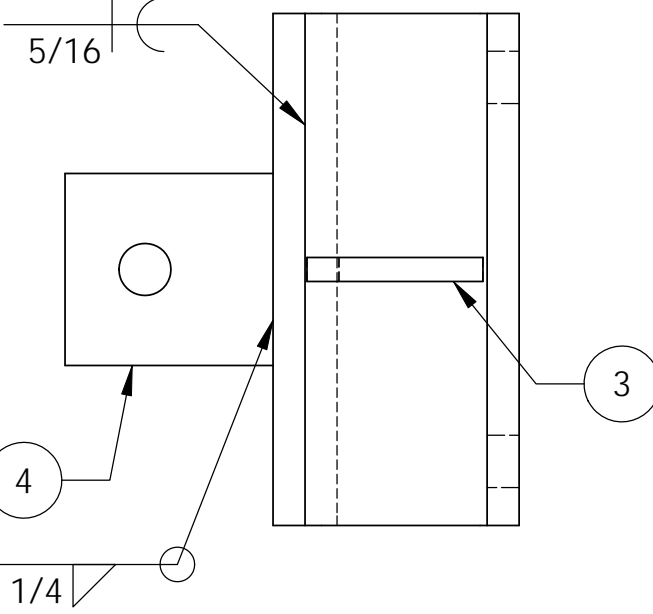
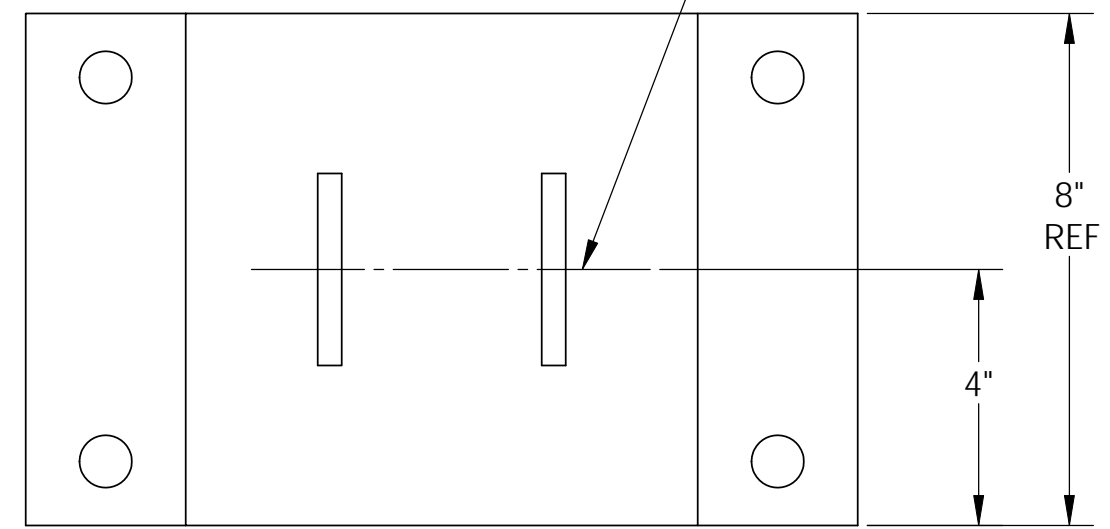

2 PLACES

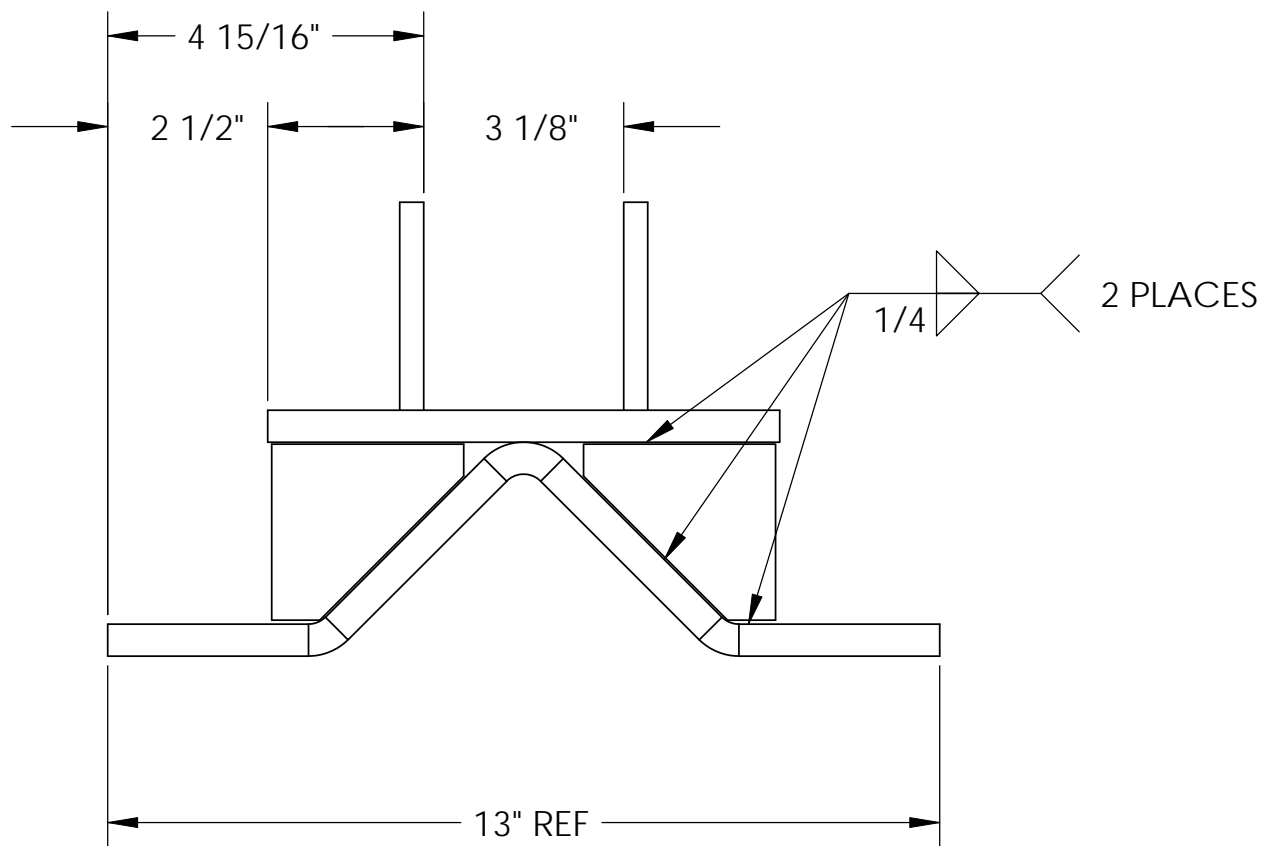

ITEM NO.	PART NUMBER	DESCRIPTION	QTY.
1		MOUNT PLATE	1
2		MOUNT V PLATE	1
3		MOUNT GUSSET	2
4		LEG MOUNT EAR	2

UNLESS OTHERWISE SPECIFIED:
 DIMENSIONS ARE IN INCHES
 TOLERANCES:
 FRACTIONAL ± 1/32
 ANGULAR: MACH ± 25° BEND ± 5°
 TWO PLACE DECIMAL ± .03
 THREE PLACE DECIMAL ± .010

TASHJIAN TOWERS CORPORATION

TITLE: MOUNT PLATE WELDMENT

CHECKED	DATE	NAME	COMMENTS:
DRAWN	02/09/09	TAM	
ENG APPR.			
Q.A.			
MFG APPR.			

PROPRIETARY AND CONFIDENTIAL
 THE INFORMATION CONTAINED IN THIS DRAWING IS THE SOLE PROPERTY OF TASHJIAN TOWERS CORP. ANY REPRODUCTION IN PART OR AS A WHOLE WITHOUT THE WRITTEN PERMISSION OF TASHJIAN TOWERS CORP. IS PROHIBITED.

NEXT ASSY	USED ON	FINISH	ASTM A123 GALV
APPLICATION			

SIZE **B** DWG. NO. REV
 SCALE: 1:3 WEIGHT: SHEET 1 OF 1

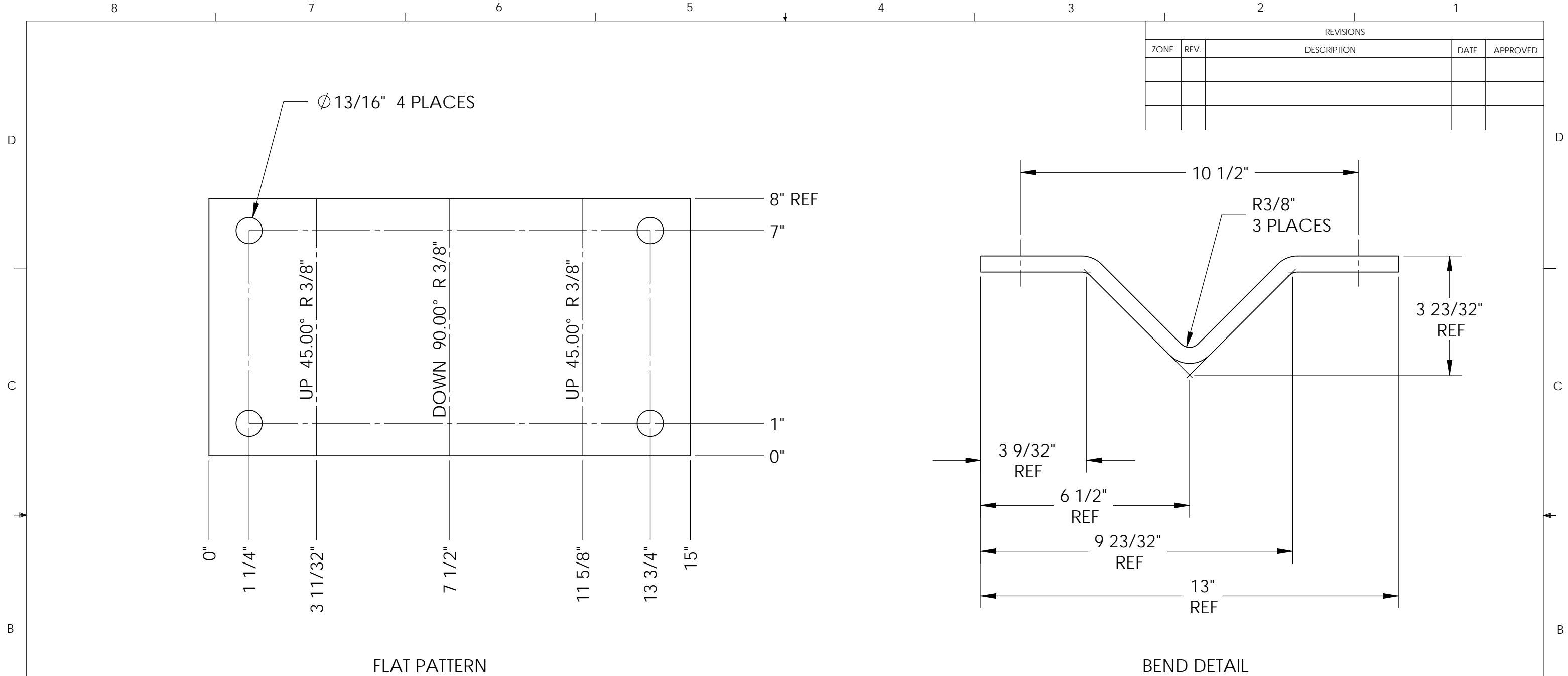

FLAT PATTERN

BEND DETAIL

ALT MAT'L: PLATE, 1/2 HR ASTM A36 STEEL

	1.083	FT		MATERIAL: BAR, 1/2 X 8 HR ASTM A36 STEEL
ITEM	QTY	UNIT	PART NO.	DESCRIPTION
				UNLESS OTHERWISE SPECIFIED: DIMENSIONS ARE IN INCHES TOLERANCES: FRACTIONAL ± 1/32 ANGULAR: MACH ± .25° BEND ± .5° TWO PLACE DECIMAL ± .03 THREE PLACE DECIMAL ± .010
				TASHJIAN TOWERS CORPORATION
				TITLE: MOUNT V PLATE
				CHECKED DATE NAME COMMENTS: DRAWN 02/09/09 TAM
				ENG APPR. Q.A. MFG APPR.
				SIZE DWG. NO. REV B
				SCALE: 1:3 WEIGHT: SHEET 1 OF 1

PROPRIETARY AND CONFIDENTIAL
THE INFORMATION CONTAINED IN THIS DRAWING IS THE SOLE PROPERTY OF TASHJIAN TOWERS CORP. ANY REPRODUCTION IN PART OR AS A WHOLE WITHOUT THE WRITTEN PERMISSION OF TASHJIAN TOWERS CORP. IS PROHIBITED.

8 7 6 5 4 3 2 1

REVISIONS				
ZONE	REV.	DESCRIPTION	DATE	APPROVED

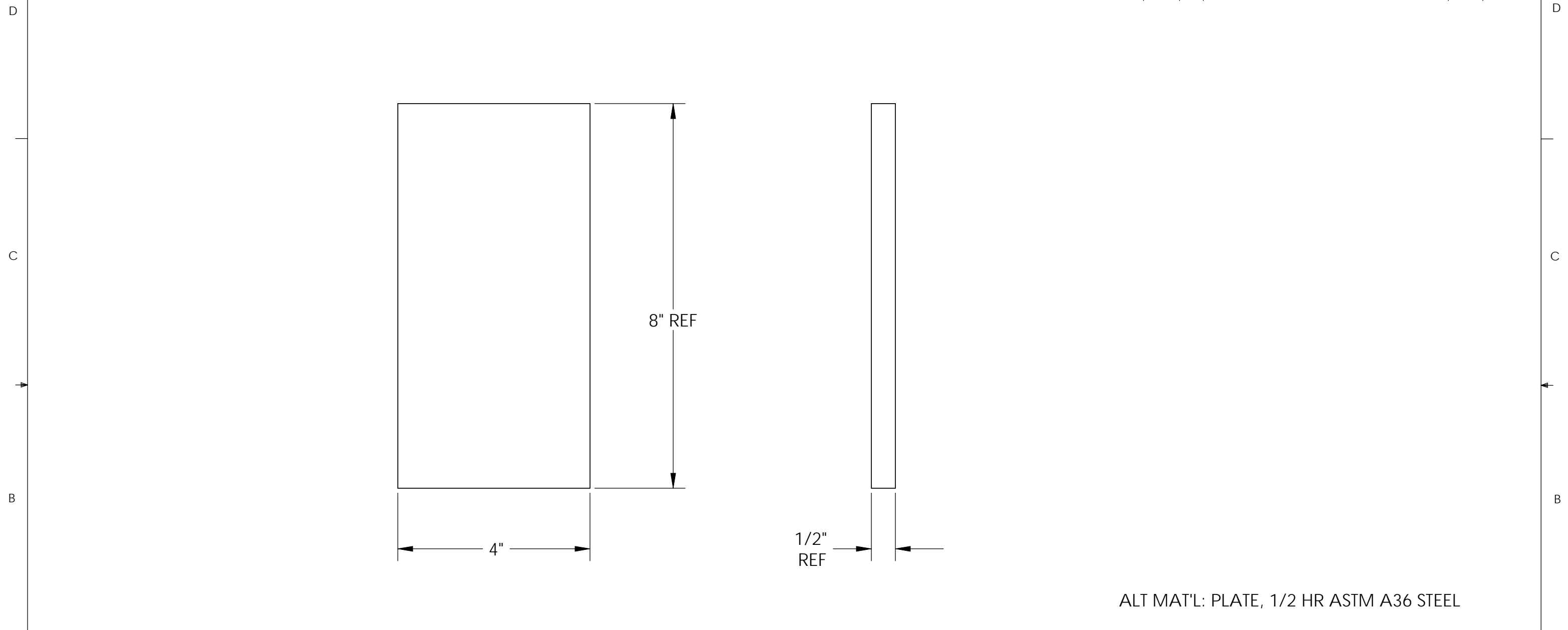

ALT MAT'L: PLATE, 1/2 HR ASTM A36 STEEL

1	0.33	FT	-	BAR, 1/2 X 8 HR ASTM A36 STEEL																				
ITEM	QTY	UNIT	PART NO.	DESCRIPTION																				
				UNLESS OTHERWISE SPECIFIED: DIMENSIONS ARE IN INCHES TOLERANCES: FRACTIONAL ± 1/32 ANGULAR: MACH ± .25° BEND ± .5° TWO PLACE DECIMAL ± .03 THREE PLACE DECIMAL ± .010																				
				INTERPRET GEOMETRIC TOLERANCING PER:																				
				MATERIAL AS NOTED																				
				FINISH																				
				APPLICATION																				
<p>TASHJIAN TOWERS CORPORATION</p> <p>TITLE: MOUNTING TUBE END PLATE</p>				<table border="1"> <tr> <td>CHECKED</td> <td>DATE</td> <td>NAME</td> <td>COMMENTS:</td> </tr> <tr> <td>DRAWN</td> <td>02/09/09</td> <td>TAM</td> <td> </td> </tr> <tr> <td>ENG APPR.</td> <td> </td> <td> </td> <td> </td> </tr> <tr> <td>Q.A.</td> <td> </td> <td> </td> <td> </td> </tr> <tr> <td>MFG APPR.</td> <td> </td> <td> </td> <td> </td> </tr> </table>	CHECKED	DATE	NAME	COMMENTS:	DRAWN	02/09/09	TAM		ENG APPR.				Q.A.				MFG APPR.			
CHECKED	DATE	NAME	COMMENTS:																					
DRAWN	02/09/09	TAM																						
ENG APPR.																								
Q.A.																								
MFG APPR.																								
				<table border="1"> <tr> <td>SIZE</td> <td>DWG. NO.</td> <td>REV</td> </tr> <tr> <td>B</td> <td>-</td> <td> </td> </tr> </table>	SIZE	DWG. NO.	REV	B	-															
SIZE	DWG. NO.	REV																						
B	-																							
				<table border="1"> <tr> <td>SCALE: 1:2</td> <td>WEIGHT:</td> <td>SHEET 1 OF 1</td> </tr> </table>	SCALE: 1:2	WEIGHT:	SHEET 1 OF 1																	
SCALE: 1:2	WEIGHT:	SHEET 1 OF 1																						

PROPRIETARY AND CONFIDENTIAL
THE INFORMATION CONTAINED IN THIS DRAWING IS THE SOLE PROPERTY OF TASHJIAN TOWERS CORP. ANY REPRODUCTION IN PART OR AS A WHOLE WITHOUT THE WRITTEN PERMISSION OF TASHJIAN TOWERS CORP. IS PROHIBITED.

8 7 6 5 4 3 2 1

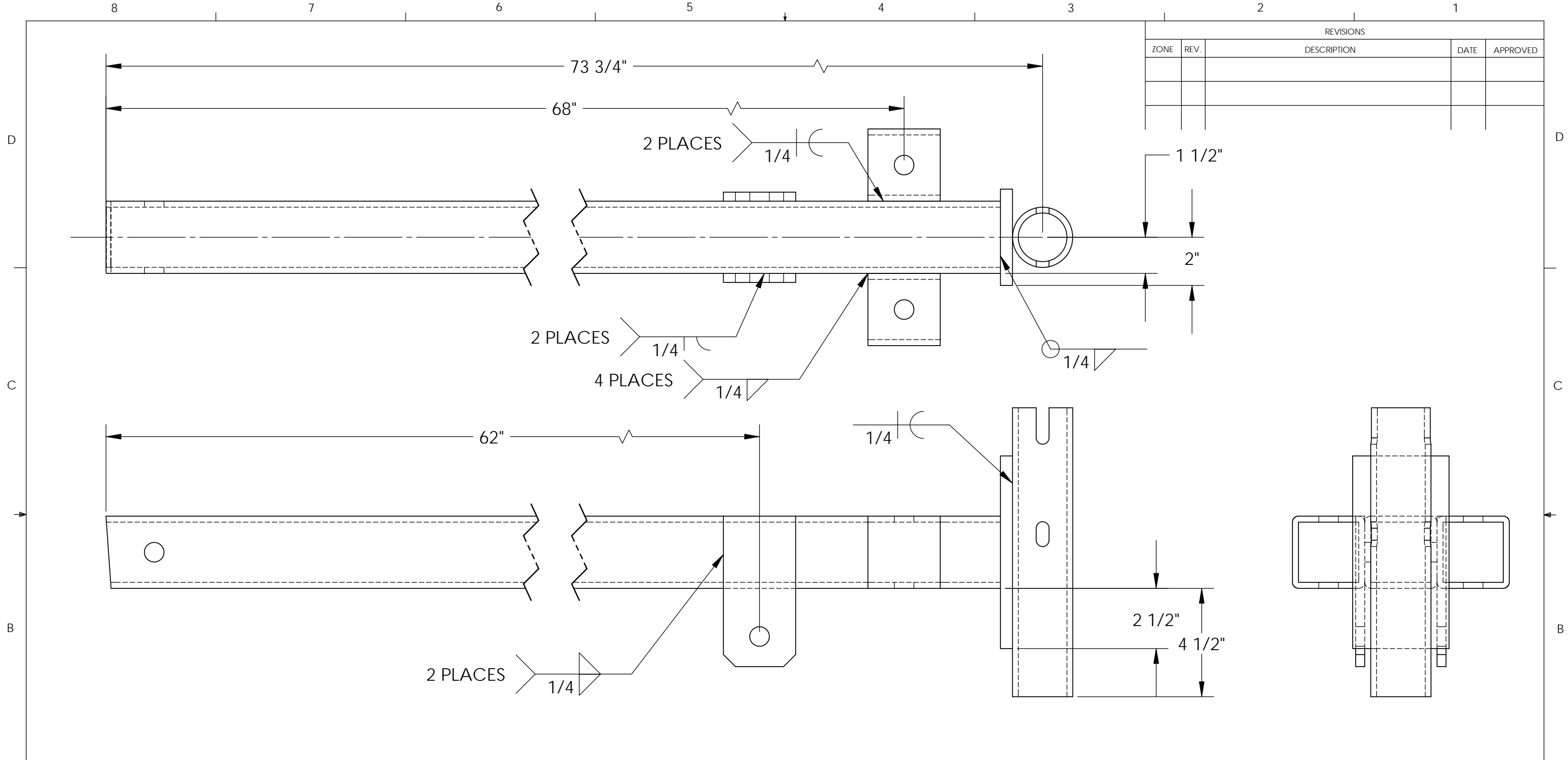

REVISIONS				
ZONE	REV.	DESCRIPTION	DATE	APPROVED

ITEM NO.	PART NUMBER	DESCRIPTION	QTY.
1		MOUNTING TUBE	1
2		MOUNTING TUBE END PLATE	1
3		MOUNTING TUBE END PIPE	1
4		DIAGONAL BRACE MOUNTING EAR	2
5		KICK BRACE MOUNTING TUBE	2

PROPRIETARY AND CONFIDENTIAL
 THE INFORMATION CONTAINED IN THIS DRAWING IS THE SOLE PROPERTY OF TASHJIAN TOWERS CORP. ANY REPRODUCTION IN PART OR AS A WHOLE WITHOUT THE WRITTEN PERMISSION OF TASHJIAN TOWERS CORP. IS PROHIBITED.

UNLESS OTHERWISE SPECIFIED:		TASHJIAN TOWERS CORPORATION		
DIMENSIONS ARE IN INCHES				
TOLERANCES:		TITLE: STAND OFF MOUNT TUBE WELDMENT		
FRACTIONAL ± 1/32		CHECKED	DATE	NAME
ANGULAR: MACH ± .25° BEND ± .5°		DRAWN	02/09/09	TAM
TWO PLACE DECIMAL ± .03		ENG APPR.		
THREE PLACE DECIMAL ± .010		Q.A.		
INTERPRET GEOMETRIC TOLERANCING PER:		MFG APPR.		
MATERIAL AS NOTED		SIZE	DWG. NO.	REV
FINISH ASTM A123 GALV		B	-	
NEXT ASSY	USED ON	SCALE: 1:4		WEIGHT:
APPLICATION		SHEET 1 OF 1		